

Cold-Formed Steel Load Bearing Wall Bridging

technical note

MECHANICAL BRIDGING AND BRIDGING ANCHORAGE OF LOAD BEARING COLD-FORMED STEEL STUDS

By: Paul Lackey, EIT, Nabil A. Rahman, PhD, P.E. and Gary Bennett



The Steel Network, Inc.
2012 T.W. Alexander Drive
PO Box 13887
Durham, NC 27709
Phone: (888) 474-4876
www.steelnetwork.com

MECHANICAL BRIDGING AND BRIDGING ANCHORAGE OF LOAD BEARING COLD-FORMED STEEL STUDS

**Paul E. Lackey, EIT
Nabil A. Rahman, Ph.D., PE
Gary Bennett**

INTRODUCTION

The purpose of this technical note is to provide a clear understanding on the design requirements and methods of laterally bracing (bridging) load bearing cold-formed steel stud walls. Cold-Formed Steel (CFS) studs provide a cost effective and extremely efficient structural solution for the typical mid-rise building. In recent decades CFS design has evolved tremendously as the behavior and design constraints of the material continue to be better defined through research and testing. As previous limitations on the load capacities of CFS studs continue to evolve, the height of the typical mid rise CFS structure is also rising, making it critical to the integrity of the structure that these heavily loaded studs be properly braced.

A CFS stud in compression can fail in one or a combination of the following: local buckling, distortional buckling, or global buckling. Both local and distortional buckling are localized failures of the elements making up the cross section of the stud. These localized failures cannot be prevented by the use of common mechanical bridging and bracing methods. Global buckling of an axially loaded stud can occur in one of three modes: flexural buckling, torsional buckling, or torsional-flexural buckling. In order to prevent global buckling about the weak axis of the stud, bridging is used within the plane of the wall and specific performance requirements of the bridging must be maintained.

The bridging methods described herein represent a mechanical bracing design consistent with the all steel design approach described by AISI 2001, Section D4. A sheathing braced design approach may also be used with specific design provisions set forth by AISI, but will not be discussed as a part of this technical note. In addition the primary interest of the bridging discussion will revolve around axially loaded studs only. The bridging requirements for studs loaded laterally, perpendicular to the plane of the wall are not discussed.

DESIGN REQUIREMENTS

The design requirements for the bridging components of cold formed steel studs are described by the American Iron and Steel Institute (AISI). The 2001 edition of the AISI North American Specification (NAS) is referenced by both the 2003 & 2006 International Building Codes (IBC). AISI has recently released a 2007 edition of the North American Specification which will be referenced beginning in the 2009 IBC. Both the current and future code requirements are described in the subsequent sections. The theory and origin of the code requirements are beyond the scope of this technical note, but a non-inclusive list of additional resources has been included at the end of this section for further research into this topic.

Current Code Requirements

AISI Standard – Wall Stud Design (2004 Edition). Section C5.1 states:

“For axial loaded members, each intermediate brace shall be designed for 2% of the design compression load in the member. For combined bending and axial loads, each intermediate brace shall be designed for the combined brace force determined in accordance with Section D3.2.2 of the *Specification* and 2% of the design compression load in the member.”

AISI North American Specification for the Design of Cold-Formed Steel Structural Members (2001 Edition), Section D3.2.2 states:

“Each intermediate brace, at the top and bottom flange, shall be designed to resist a required lateral force, P_L , determined as follows:

(a) For uniform loads, $P_L = 1.5K'$ times the design load (nominal loads for ASD, factored loads for LRFD and LSD) within a distance $0.5a$ each side of the brace.

For C-Sections: $K' = m/d$ Where,
 m = Distance from shear center to mid-plane of web
 d = Depth of C-Section
 a = Distance between center line of braces

The required bracing design strength of 2% of the axial load is based on long standing industry practice (AISI WSD 2004). The bracing forces are assumed to accumulate within the bridging line at each stud. This topic is covered in greater detail in the “Anchoring of Bridging” section of this technical note.

Future Code Requirements

The implementation of the AISI 2007 specification into future local and state building codes will bring a reduction in the strength required of the bridging member to brace the stud, but will require a minimum stiffness of the brace:

AISI North American Specification for the Design of Cold-Formed Steel Structural Members (2007 Edition), Section D3.3 states:

The required brace strength to restrain lateral translation at a brace point for an individual compression member shall be calculated as follows:

$$P_{br,1} = 0.01P_n$$

The required brace stiffness to restrain lateral translation at a brace point for an individual compression member shall be calculated as follows:

$$\beta_{br,1} = \frac{2[4 - (2/n)]P_n}{L_b}$$

$P_{br,1}$ = Required nominal brace strength [resistance] for a single compression member

P_n = Nominal axial compression strength [resistance] of a single compression member

$\beta_{br,1}$ = Required brace stiffness for a single compression member

n = Number of equally spaced intermediate brace locations

L_b = Distance between braces on one compression member

Additional Resources

Galambos, T.V., (1998). *Guide to Stability Design Criteria for Metal Structures*, 5th edition, John Wiley & Sons, Inc., New York.

Green, P., T. Sputo and V. Urala (2004). "Strength and Stiffness of Conventional Bridging Systems for Cold-Formed Cee Studs." Proceedings of the Seventeenth International Specialty Conference on Cold-Formed Steel Structures, University of Missouri-Rolla, Rolla, MO, November 2004.

Sputo, T. and J. Turner (2004). "Bracing Cold-Formed Steel Structures: A Design Guide", Structural Engineering Institute, December 2004.

BRIDGING METHODS

Several methods are available to accomplish effective bracing of a cold formed steel stud against both buckling and rotation. The methods may be categorized into three different groups: tension systems, tension-compression systems, and compression systems. Regardless of the bridging system type used, the bridging must be effectively continuous between anchorage points. Engineered splice details are required to maintain the performance requirements of the bridging along the length of the entire wall.

In a tension system the member used for bridging the stud is designed to resist the stud buckling in pure tension. An example of a pure tension system consists of flat strap attached to both flanges of the stud with blocking at intervals within the wall to provide resistance to the rotation tendency of the studs within the wall. The flat strap is typically attached to each stud flange with a pre-determined number of screws. The blocking is set at the required calculated intervals determined by the engineer to resist the rotation and is attached to the flat strap on each side of the wall as shown in Figure 1. This type of bridging is advantageous in scenarios requiring a significant number of mechanical and electrical utilities within the wall plane. However, because installation requires access to both sides of the wall, this approach causes potential problems for installation in exterior walls. Additionally, the flat strap must be installed taut or it will not effectively resist buckling of the stud.

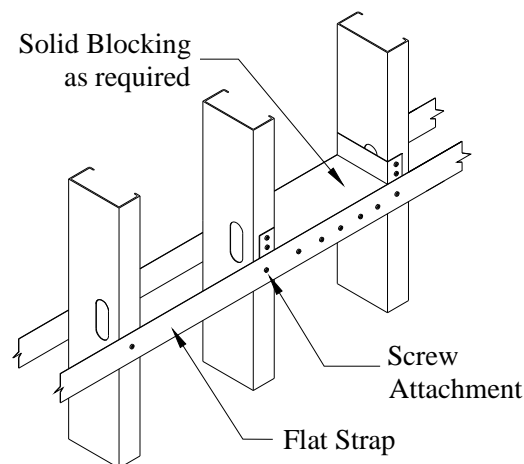

Figure 1: Flat Strap Bridging System

A bridging system may also have the capability to resist the buckling of the stud in a combination of both tension and compression. Two examples of this type of system are cold rolled channel and proprietary BridgeBar[®] 150 threaded through the knockouts of the stud with a clip attaching the bridging member to the stud as shown in Figure 2. The clip is responsible for transferring the load induced from the lateral buckling of the stud into the bridging line, as well as transferring the moment induced from the rotation of the stud into the bridging line. A static analysis suggests that the cold rolled channel and BridgeBar[®] 150 function in 50% compression and 50% tension between “anchorage” points. This concept is illustrated in the Design Example given within this technical note. The typical cold rolled channel member used for a load bearing stud wall application is a 1½” x ½” x 54mil, 33 ksi section. BridgeBar[®] 150 is made from 33 mil, 50 ksi material. This bridging method requires access to only one side of the stud wall for installation. The stud knockouts must align horizontally for the channel to thread continuously throughout the wall length.

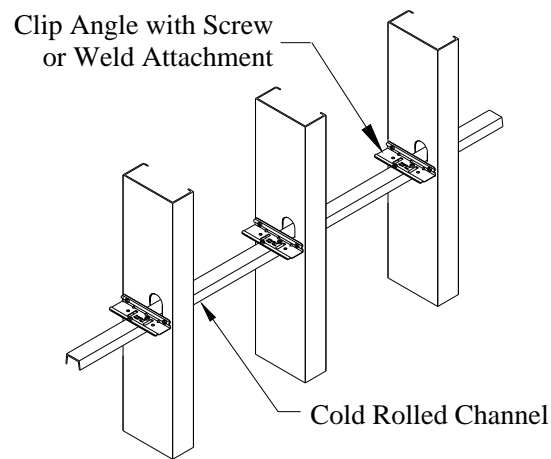

Figure 2: Cold Rolled Channel Bridging System

The third classification of bridging system is a compression only system. A compression only system is capable of resisting stud buckling in compression only. An example of a compression bridging system with both a high compressive load capacity and stiffness is the proprietary bridging member BuckleBridge[®]. BuckleBridge[®] is capable of functioning in compression only due to its method of attachment to the stud. BuckleBridge[®] is attached through two lips into the web of the stud with screws in each lip as shown in Figure 3. Because the screws would be required to function in pullout for the system to function in tension, the system in tension has limited resistance to stud buckling. This system may be easily installed, and pieces interlock together using a tongue and groove configuration.

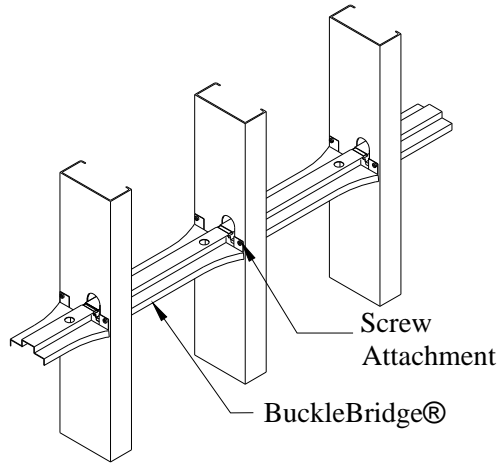

Figure 3: BuckleBridge® Bridging System

ANCHORING OF BRIDGING

As previously mentioned, current AISI design standards require a force in the bridging line equal to 2% of the stud axial load to resist lateral buckling about the weak axis at each stud location. The bridging force accumulates at each stud location along the wall line and must be removed periodically as the load in the bridging reaches the allowable capacity of the bridging method used (AISI 2004). The mechanism for removing the bridging loads is known as the “anchorage” point of the bridging. The method of bridging anchorage will vary depending on the amount of load accumulated in the bridging row and the preference of the design engineer. Figure 4 describes the accumulation of the bridging force. This section describes several common methods of bridging anchorage.

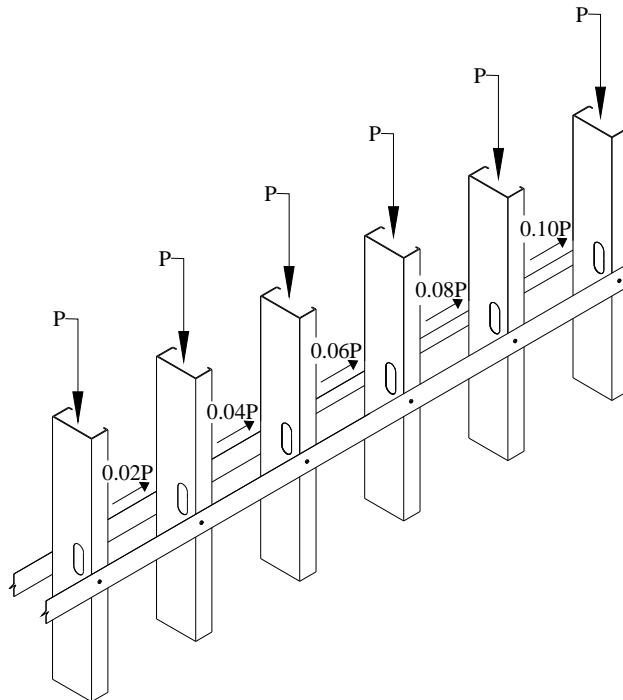

Figure 4: Accumulation of Bridging Force in Bridging Row

One of the more common methods of bridging anchorage consists of flat strap cross bracing attached from the bridging line to the top and bottom of the wall on each side of the stud. The thickness and width of the flat strap will vary depending on the loading requirements. For this type of system the design engineer should specify the strap size as well as the connection requirements at both the bridging line and at the floor system. The system functions in tension only to transfer bridging loads to the floor system. A cross bracing pattern is required to anchor stud bridging for buckling in either direction of the wall. Figure 5 shows the flat strap anchorage method applicable to the BuckleBridge® bridging system. The concept of this anchorage system can be used with all common bridging methods.

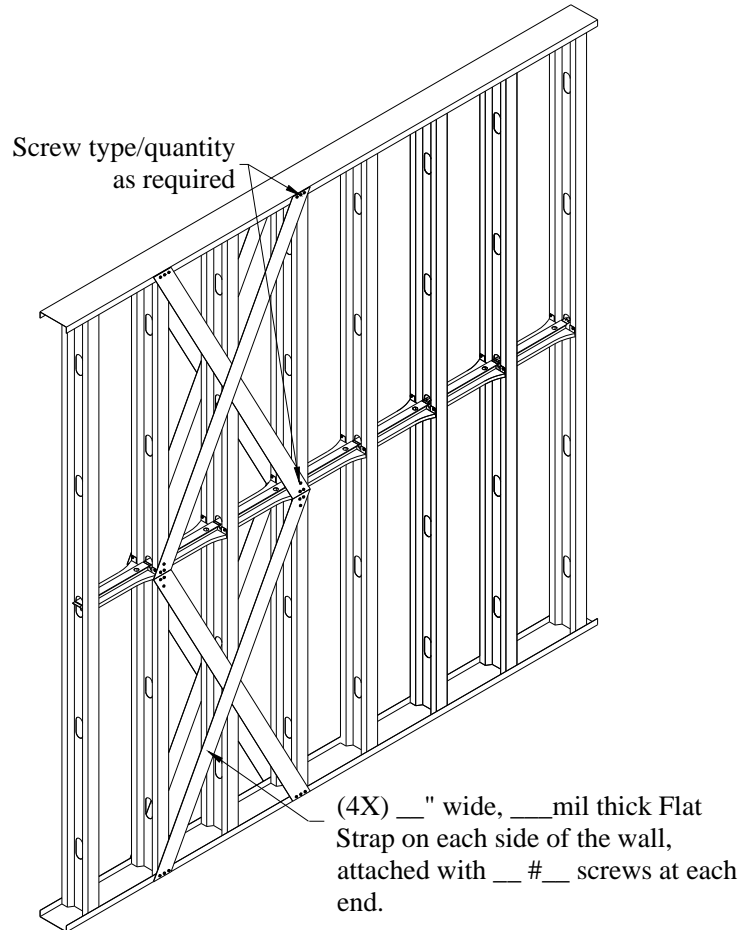

Figure 5: Anchorage of Bridging Using Flat Strap Cross Bracing

An alternative bridging method consists of a stud oriented so that the strong axis is perpendicular to the bridging row and attached to both the bridging line and the top/bottom of the wall. The stud acts in bending about its strong axis and transfers the bridging loads into the floor system through a series of clips as shown in Figure 6. The design engineer must specify the stud type and connections to be used based on the cumulative force in the bridging. This type of anchorage system may be used with a flat strap bridging method by attaching the web of a stud to the flat strap on each side of the wall as well as to the top and bottom track.

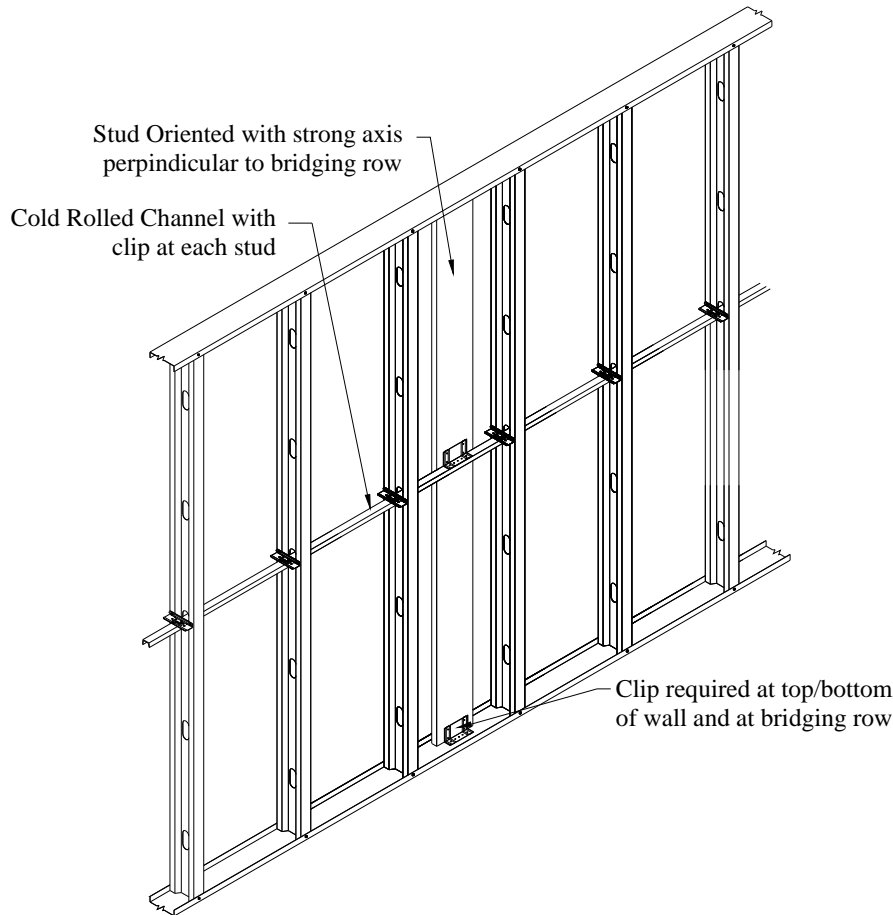

Figure 6: Anchorage of Bridging Using a Stud in Bending

Another common method of bridging anchorage is with a built up stud section placed at specific intervals within the stud wall as shown in Figure 7. The built up stud section should be capable of resisting the applicable axial load as an un-braced section, as well as resist the cumulative bridging row force within the plane of the wall. The stress interaction must be checked for the axial loads and the bending loads induced from the bridging row as well as any wind or internal pressure acting on the stud.

The use of bridging anchorage is critical to ensure that the tendency of the studs to buckle about the weak axis is restrained by the bridging. The type of bridging method used will determine the anchorage spacing and the available anchorage methods for each specific bridging system. It should be pointed out that the bridging methods which are capable of resisting load in both tension and compression depending on the wall length may require a single anchorage point within the wall. However, tension only and compression only bridging systems will always require a minimum of two anchorage locations within the wall length to resist the buckling of the wall in either direction.

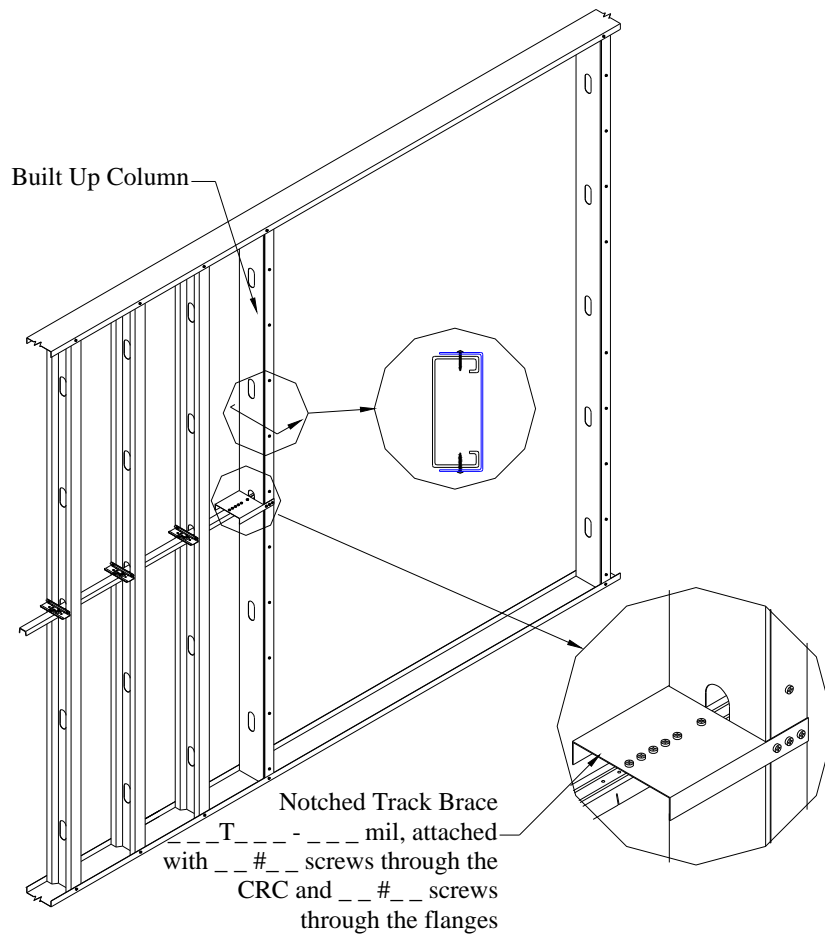

Figure 7: Anchorage of Bridging Using a Built Up Section

DESIGN EXAMPLE

Design Criteria

Bridging System: BridgeBar[®] 150 (BB 150) (50% tension and 50% compression)

Axial Load Per Stud: 10 kips (a stud subjected to only axial load is considered)

Stud Height: 10'

Bridging Height: 60", One row at mid span

Bridging Anchorage Method: Stud oriented with strong axis perpendicular to bridging
 Studs at 16" o.c.

Code Requirement: 2% of axial load in stud required for bracing (2001 AISI NAS)

Allowable Stress Design (ASD)

Solution

2% of axial load (10 kips) = 200 lbs

Design Attachment of Stud to BridgeBar[®] 150 to Transfer 2% of axial load into bridging

Load req. = 200 lbs

Use BC800 by The Steel Network, Inc.
Allowable Load = 360 lbs (LBWS, 2008)

Determine Anchorage Requirements

Axial Compression Capacity of BB[®] 150 for 16" length = 0.9 kips (LBWS, 2008)

Axial Tension Capacity of BB[®] 150 is less of $\frac{A_g F_y}{\Omega = 1.67}$ or $\frac{A_n F_u}{\Omega = 2.0}$

$$\frac{A_g F_y}{\Omega = 1.67} = \frac{(0.099)(50)}{1.67} = 2.96 \text{ kips}$$

$$\frac{A_n F_u}{\Omega = 2.0} = \frac{(0.068)(65)}{2} = 2.21 \text{ kips, governs tension capacity}$$

Since Compression Capacity will govern, $900 / 200 = 4.5$ Studs

Using 4 studs in tension, 4 studs in compression; anchorage required every 8 studs

8 studs = 10' 8" of wall length

At the anchorage location the bridging force = $200 * 8 = 1,600$ lbs.

Design a 10' stud for anchoring the bridging with a 1600 lb point load at 5'

$$\text{Moment in Stud, } M = PL/4 = \frac{1600(10)}{4} = 4000 \text{ lb-ft} = 48 \text{ k-in.}$$

Shear in Stud, $V = P/2 = 1600/2 = 800$ lbs = 0.8 kips

Use 800S200-68, 50 ksi, non perforated stud

Allowable Moment $M_a = 52.9$ k-in. (SSS 5.0)

Allowable Shear $V_a = 3.4$ kips (SSS 5.0)

-Allowable moment/shear based on lateral torsional bracing at 60" o.c.

Design the connection of the anchor stud, 800S200-68, to the bridging row

Force required, $P = 1,600$ lbs

Use StiffClip® AL800 by The Steel Network, Inc.,

-Attachment of Clip to Stud

From TSN Load Tables Use (4) #12 screws for clip to stud (Pa = 2,955 lbs)(LSFC, 2009)
Secondary shear resulting from torsional moment is accounted for in TSN tables

-Attachment of Clip to BB® 150

Determine direct and secondary shear in fasteners

Try (7) fasteners,

Direct Shear on Screws = 1600 lbs / 7 = 229 lbs

Calculate Secondary Shear on screws with spacing as given,

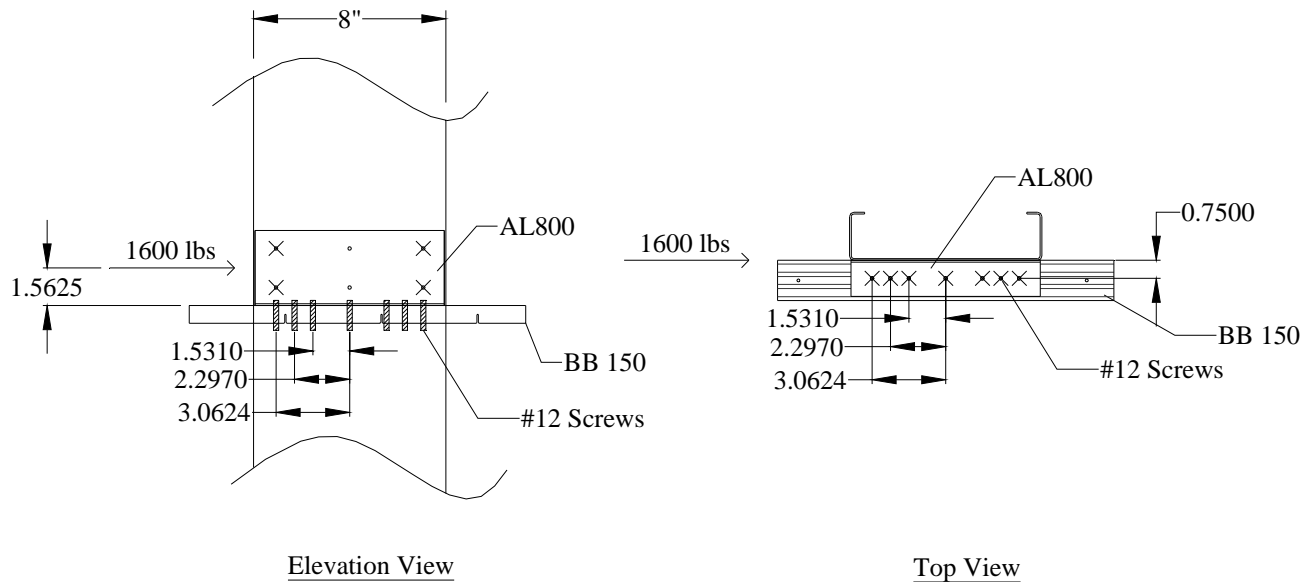

Moment of Inertia of Screw Group, I_s

$$I_s = 1.531^2(2) + 2.297^2(2) + 3.0624^2(2) = 34 \text{ in.}^2$$

Resulting Torsional Moment in Screw Group = 1600 * (0.75) / 2 = 600 lb – in.

Max Secondary Shear in Screw = $M_t y / I_s = 600 (3.0624) / 34 = 54.04 \text{ lb}$

$$\text{Resultant Shear in Screw} = \sqrt{229^2 + 54.04^2} = 235.3 \text{ lbs}$$

#12 screw allowable shear for clip (68 mil) to BB[®] 150 (33 mil) = 272 lbs (SSS 5.0)

Use (7) #12 screws clip to BB[®] 150

Allowable Shear per screw, $V_a = 272 \text{ lbs} > 235.3 \text{ lbs}$ OK

Design the connection of the stud to floor system top and bottom

Force required, $P = 800 \text{ lbs}$

Use StiffClip[®] AL800 by The Steel Network, Inc. (TSN).

-Attachment of Clip to Stud

From TSN Load Tables Use (2) #12 screws for clip to stud ($P_a = 1,482 \text{ lbs}$)(LSFC, 2009)
Secondary shear resulting from torsional moment is accounted for in TSN tables

-Design anchorage to floor system assuming concrete $f'_c = 4,000 \text{ lbs}$

Determine direct and secondary shear in fasteners

Try (3) Hilti X-U fasteners,

Direct Shear on Screws = $800 \text{ lbs} / 3 = 267 \text{ lbs}$

Calculate Secondary Shear on screws with spacing as given,

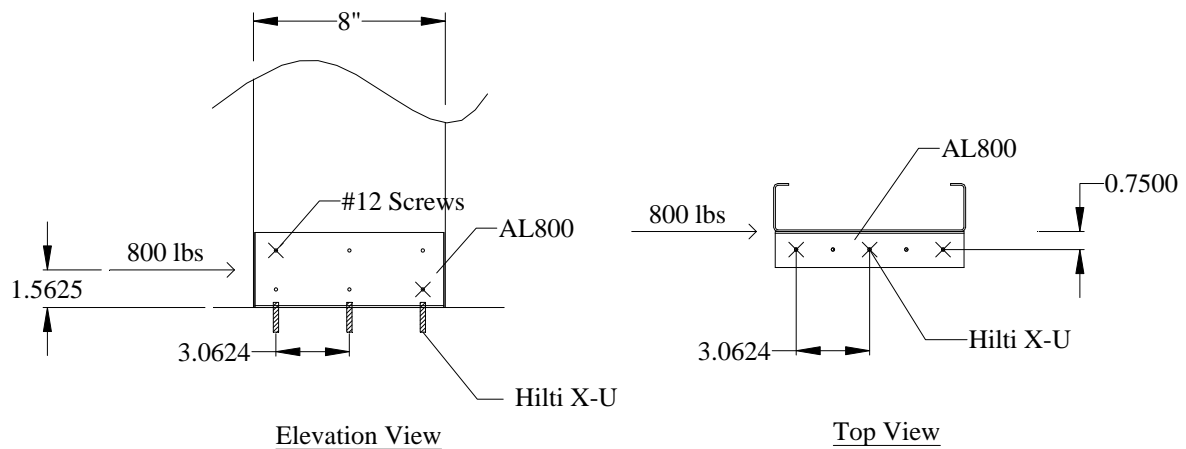

Moment of Inertia of Screw Group, I_s

$$I_s = 3.0624^2(2) = 18.76 \text{ in.}^2$$

Resulting Torsional Moment in Screw Group = $800 * (0.75) / 2 = 300 \text{ lb} - \text{in.}$

Max Secondary Shear in Screw = $M_{ty} / I_s = 300 (3.0624) / 18.76 = 49 \text{ lb}$

Resultant Shear in Fasteners = $\sqrt{267^2 + 49^2} = 271.5 \text{ lbs}$

Hilti X-U Fasteners shear capacity (1½" embedment) = 420 lbs (Hilti, 2008)

Use (3) Hilti X-U Fasteners

Allowable Shear per fastener, $V_a = 420 \text{ lbs} > 271.5 \text{ lbs}$ OK

Design Example Summary

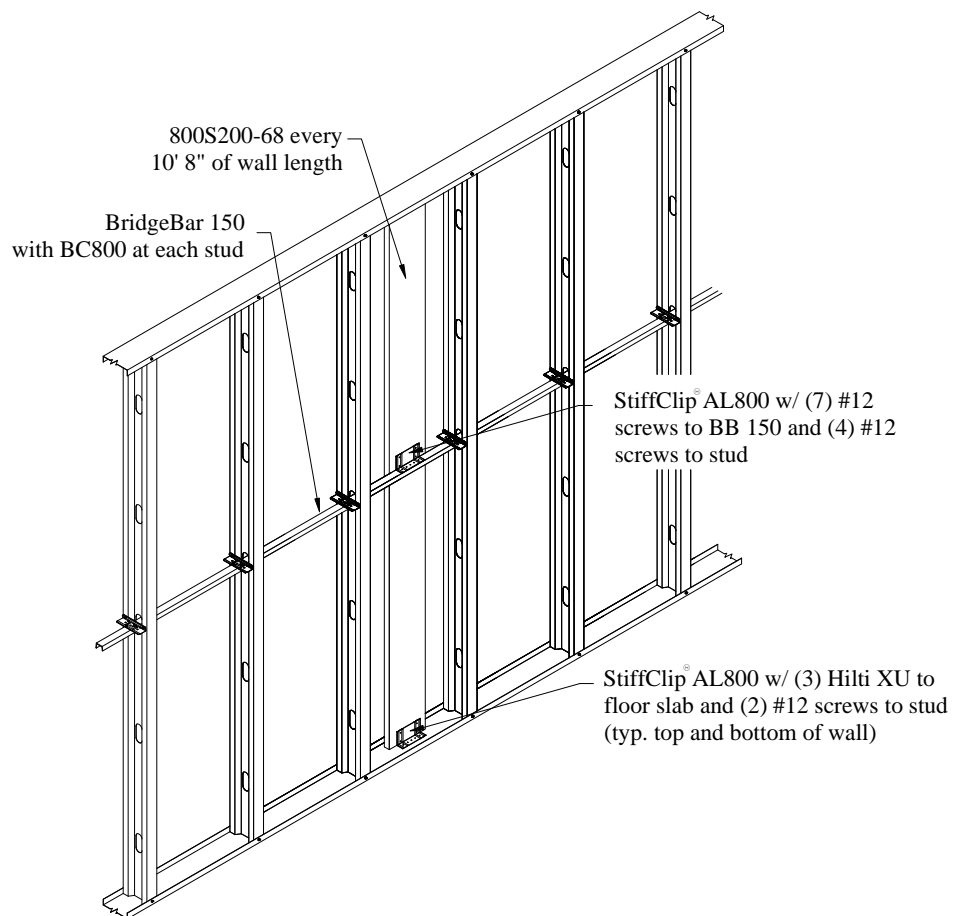

CLOSING REMARKS

The use of cold formed steel as the primary structural system in mid-rise construction has become increasingly popular over the last decade. To ensure the integrity of the structure the design engineer must fully understand the behavior and bracing requirements of a CFS load bearing stud. An integral part of the bracing requirements is the bridging required in the wall to prevent the tendency of a cold formed steel stud to buckle about its weak axis under increasing load. For the bridging to be effective, it must be anchored periodically as the accumulation of the bridging force approaches the allowable capacity of the bridging method used. The contents of this technical note have offered an overview of the current code requirements for the buckling resistance, as well as provided information on some of the common methods of achieving the bracing requirements.

REFERENCES

- American Iron and Steel Institute, “Cold-Formed Steel Framing Design Guide – Design Guide D110-07.” Second Edition, December 2007, Washington, DC
- American Iron and Steel Institute, “North American Specification for the Design of Cold-Formed Steel Structural Members”, AISI Standard, 2001 Edition, Washington, DC
- American Iron and Steel Institute, “Supplement 2004 to the North American Specification for the Design of Cold-Formed Steel Structural Members 2001 Edition.” January 2005, Washington, DC
- American Iron and Steel Institute, “North American Specification for the Design of Cold-Formed Steel Structural Members”, AISI Standard, 2007 Edition, Washington, DC
- American Iron and Steel Institute, “Standard for Cold-Formed Steel Framing – Wall Stud Design (WSD)”, 2004 Edition, Washington, DC
- Hilti, North American Product Technical Guide, 2008 Edition
- Light Steel Framing Connections Catalog (LSFC), The Steel Network, Raleigh, NC, February 2009
- Load Bearing Wall Systems Catalog (LBWS), The Steel Network, Raleigh, NC, June 2008
- Steel Smart System 5.0 (SSS 5.0), Cold Formed Steel Design Software Version 5.1.0.3, Applied Science International, Raleigh, NC